

MAC16*A

SIGNATURE SERIES

SPLIT AIR CONDITIONER SYSTEM
UP TO 16 SEER



COMPRESSOR

- High-efficiency scroll compressor
- R410A refrigerant
- Heavy-duty compressor sound blanket for quiet operation
- Internally protected against high temperature motor overload conditions

CABINET

- Full metal louvered construction to protect the coil/ hail protection
- Individual louver panels; 4 screws to remove for ease of coil cleaning and service
- Corner-mounted controls for easy service
- Baked polyester paint finished over galvanized steel for maximum durability
- 45-degree offset valves for easy service

COILS

- CoolGuard™ total corrosion protection technology designed coil
- Enhanced tube-and-fin coil design featuring MHT™ Technology
- Lanced fins for maximum heat transfer
- Every coil factory tested for leakproof construction
- Raised coil prevents debris from impeding airflow

COMPONENTS

- Factory installed high pressure switch
- Thread-on pressure switches for simple, quick replacement
- Filter drier shipped loose for installation flexibility
- Fan orifice for smoother airflow and sound level reduction
- Charged for 15 feet of line set

WARRANTY

10 year limited warranty on compressor
10 year limited warranty on all parts, extended warranty available*

*Warranty provides for a total of 10 years of limited warranty coverage (Standard 5-year limited parts warranty plus an additional 5-year limited extended parts warranty). Warranty must be registered online within 60 days of installation to qualify for 10-year coverage. Unregistered equipment defaults to 5-year coverage. Lifetime limited heat exchanger warranty applies to registered equipment only (Standard 20 years with no online registration). See full warranty at www.mrcool.com for terms, conditions and exclusions.

NOTE:

For the latest ratings, please see
<https://www.ahridirectory.org>



MODEL NUMBER GUIDE

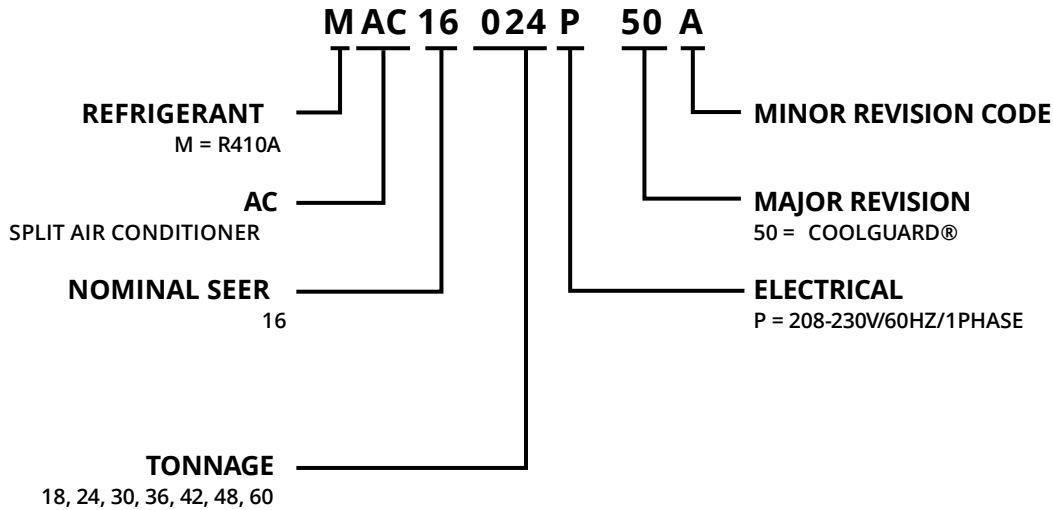

PHYSICAL AND ELECTRICAL DATA

| Model | Voltage/Hz/Phase | Voltage Range | Min. Circuit Amp. | Max. Over Current Device (amps) | Compressor | | Outdoor Fan Motor | | Shipping Weight (lbs.) |
|---------------|------------------|---------------|-------------------|---------------------------------|-------------------|---------------------|-------------------|----------|------------------------|
| | | | | | Rated Load (amps) | Locked Rotor (amps) | Rated Load (amps) | Rated HP | |
| MAC16018P-50A | 208-230/60/1 | 197-253 | 11.9 | 20 | 9 | 48 | 0.7 | 1/10 | 134 |
| MAC16024P-50A | 208-230/60/1 | 197-253 | 14.6 | 25 | 10.9 | 59 | 1 | 1/6 | 152 |
| MAC16030P-50A | 208-230/60/1 | 197-253 | 17 | 25 | 12.8 | 68 | 1 | 1/6 | 169 |
| MAC16036P-50A | 208-230/60/1 | 197-253 | 18 | 30 | 13.6 | 79 | 1 | 1/6 | 181 |
| MAC16042P-50A | 208-230/60/1 | 197-253 | 23.4 | 40 | 17.9 | 112 | 1 | 1/6 | 211 |
| MAC16048P-50A | 208-230/60/1 | 197-253 | 24.2 | 40 | 18 | 117 | 1.7 | 1/4 | 218 |
| MAC16060P-50A | 208-230/60/1 | 197-253 | 29.6 | 50 | 22.2 | 128 | 1.8 | 1/3 | 226 |

Weights listed are unit weights with packaging
 + Factory charged for 15 feet of line set. Adjust per installation instructions.

UNIT DIMENSIONS & SOUND RATINGS

| Model | Dimensions (inch) | | | Shipping Weight (Lbs.) | Sound Rating (dBA) |
|---------------|-------------------|-----------|------------|------------------------|--------------------|
| | A - Width | B - Depth | C - Height | | |
| MAC16018P-50A | 24.25 | 24.25 | 29 | 155 | 73 |
| MAC16024P-50A | 28.25 | 28.25 | 37 | 171 | 76 |
| MAC16030P-50A | 28.25 | 28.25 | 37 | 187 | 76 |
| MAC16036P-50A | 28.25 | 28.25 | 37 | 205 | 76 |
| MAC16042P-50A | 28.25 | 28.25 | 37 | 234 | 76 |
| MAC16048P-50A | 28.25 | 28.25 | 37 | 255 | 78 |
| MAC16060P-50A | 32.25 | 32.25 | 43 | 284 | 80 |

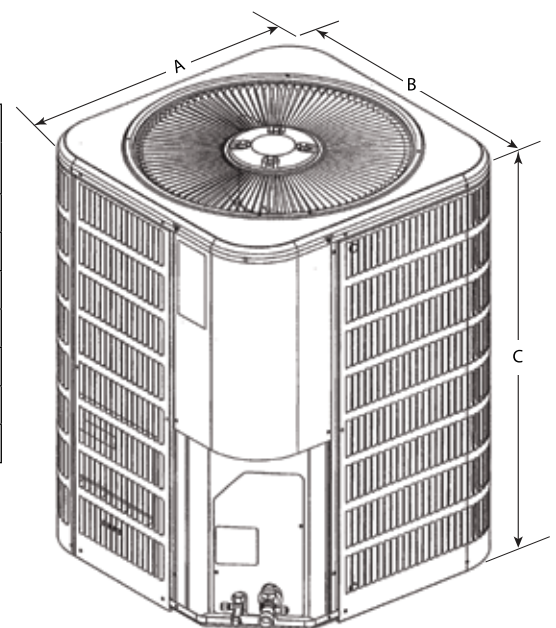

Note:
 Dimensions listed are unit sizes w/o packaging

ACCESSORIES

| Description | Where Used | Kit Number |
|-----------------------|------------------------|---------------------------|
| Crankcase Heater | All Models | 93M04 |
| Hard Start Kit | 18 | 10J42 |
| | 24, 30, 36, 42, 48, 60 | 88M91 |
| Low Ambient Kit | All Models | 34M72 |
| Short Cycle Protector | All Models | 47J27 |
| Freezestat | 3/8 Tubing | 93G35 |
| Time Delay Relay | All Models | 58M81 |
| Loss Of Charge Kit | All Models | 84M23 (Factory Installed) |
| Sound Blanket | 18, 24, 30, 36, | 14W00 (Factory Installed) |
| | 42, 48, 60 | 14W01 (Factory Installed) |
| TXV Kit | 18, 24, 30 | H4TXV01 |
| | 36, 42, 48 | H4TXV02 |
| | 60 | H4TXV03 |

REFRIGERATION DATA

| Model | Refrig. Charge (oz.) * | TXV | Refrigerant Line Size | | Outdoor Unit Connection | | Indoor Unit Connection | |
|-----------|------------------------|---------|-----------------------|--------|-------------------------|--------|------------------------|--------|
| | | | Suction | Liquid | Suction | Liquid | Suction | Liquid |
| MAC16018A | 73 | H4TXV01 | 3/4 | 3/8 | 3/4 | 3/8 | 3/4 | 3/8 |
| MAC16024A | 73 | H4TXV01 | 3/4 | 3/8 | 3/4 | 3/8 | 3/4 | 3/8 |
| MAC16030A | 88 | H4TXV01 | 3/4 | 3/8 | 3/4 | 3/8 | 3/4 | 3/8 |
| MAC16036A | 113 | H4TXV02 | 7/8 | 3/8 | 7/8 | 3/8 | 7/8 | 3/8 |
| MAC16042A | 140 | H4TXV02 | 7/8 | 3/8 | 7/8 | 3/8 | 7/8 | 3/8 |
| MAC16048A | 156 | H4TXV02 | 7/8 | 3/8 | 7/8 | 3/8 | 7/8 | 3/8 |
| MAC16060A | 192 | H4TXV03 | 1 1/8 | 3/8 | 7/8 ** | 3/8 | 7/8 | 3/8 |

*Factory charged for 15 feet of line set

** Adapter shipped with unit

NOTE:For the latest AHRI system matches please visit www.alliedratings.com or www.AHRInet.org

All specifications and illustrations subject to change without notice and without incurring obligations.